



Pneumatic Conveying of Alternative Fuels An Experience Report – From the Industry for the Industry

Schenck Process Europe GmbH is regarded as an expert in the pneumatic handling of alternative fuels. The long-established company from Darmstadt has used its rotary valve for the transport of bulky, high-wear and high-viscosity materials to develop numerous pneumatic handling systems with an injector blow-through rotary valve (IDMS).



Figure 1: Examples of different fuels: wood chips, production waste, lightweight shredder fraction, shredded tires, recycled waste, waste dusts

1 Definition of materials

1.1 Production of materials

Alternative fuels or Refuse Derived Fuels (RDF) are the end product of material processing plants. Commercial and municipal waste passes through a multi-stage comminution and preparation process here. The final grain size of the RDF (Figure 1) is determined by the shredder in the final

processing stage. A perforated plate located under the cutter rotor acts as a grading screen.

Depending on the type of shredder, its degree of comminution and the properties of the original material, each size-reduction process leaves behind a certain proportion of oversized particles. If the shredder has an integrated grading screen with a hole size of 30 mm (Figure 2), for example, the average grain size will vary from 1 to 30 mm. The permissible oversized particles from around 1 to 3 mass % can however be as large as 50 mm. So the coarser the RDF being comminuted, the more oversized particles are produced. The dimensions of the oversized particles can exceed the hole size of the grading screen by several magnitudes.

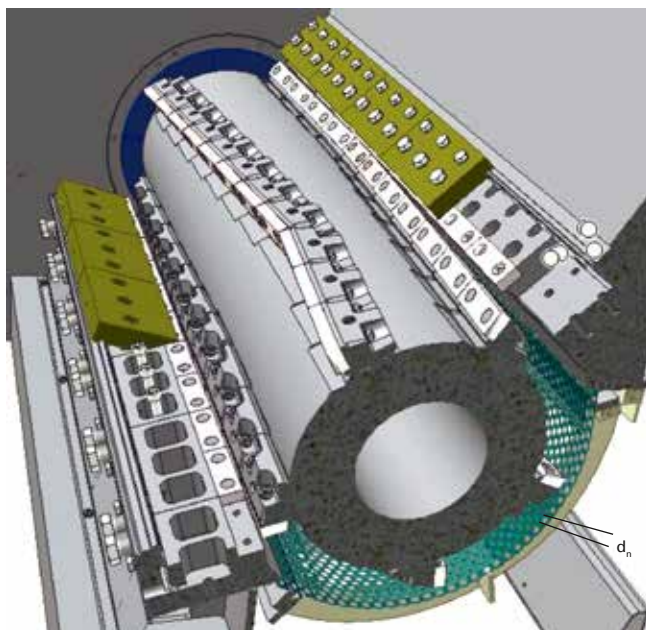

Figure 2: Shredder with integral grading screen, Lindner-Recyclingtechnik design (www.l-rt.com)

1.2 Material properties

The fibrous-flaky particle shape of RDF has a negative effect on the flow properties if large forces, and therefore internal stresses, are acting on the material. Problems occur mainly at mechanical discharge devices in the depths of the material. Typical interfaces include heaped inlets of screw gears or areas above discharge devices. Because elongated particles tend to align themselves in the longitudinal direction at right angles to the main stress under load, massive compression occurs at this point [1]. This causes large extraction forces and therefore high drive torques on the discharge elements (Figure 3). For information regarding materials handling configurations, see also [6] to [10].

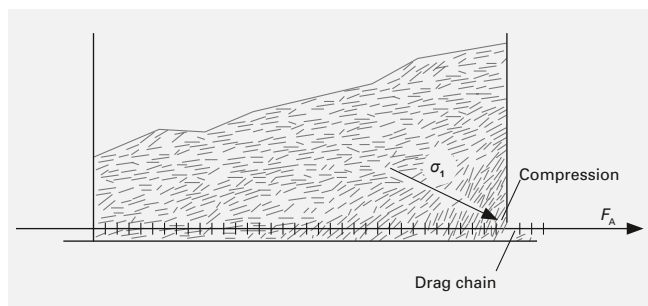

Figure 3: Extraction of flaky particles, main stress σ_1 in the compression area [1].

The effect of this alignment process is that the particles overlap even more strongly and the friction forces are increased. The particles must align and rearrange themselves along a shear plane so that shear planes can be formed.

This means that high stresses and local stress concentrations must be avoided when conveying fibrous alternative fuels (RDF).

Below is an example of a typical material specification for RDF:

Bulk material:	Waste, shredded
Bulk density:	0.1 – 0.5t/m ³
Grain size:	0 – 60mm, partially 1 – 3% to 100mm
Fines:	max. 2 – 3% < 300 μ m
Grain shape:	Two-dimensional, granular
Ash content:	max. 15%
Inert materials:	max. 5%
Iron and NF metals:	max. 0.5%
Grain size of metal parts:	max. 40mm
Moisture:	max. 20%
Temperature:	max. 80 °C
Flow properties:	Moderate to low viscosity, bridge-forming

The material specification shown here has been kept simple and satisfies most practical requirements in the field of alternative fuels.

The main material properties can be summarized as follows:

Grain size » The coarser the particle, the poorer the flow

Grain shape » The more irregular the particle, the poorer the flow

Bulk density » The lighter the particle, the poorer the flow

Moisture » The moister the particle, the poorer the flow

Grease content » The greasier and stickier the particle, the poorer the flow

Standards have been established in Europe for the material definition of alternative fuels that make it easier to check the contractual compliance of material specifications. Some of the most important standards are listed here with the sources [11] to [14].

2 Material handling

2.1 Extraction from bunkers and silos

Due to its nature, RDF is difficult to extract from bunkers and silos. The closer the chutes and inlets are to the downstream machines, the more important it becomes to control the material flow. Even small fluctuations in the material flow can cause bridging in the chutes and block machines.

Screw extractor floors, ladder floors and silo extraction screw conveyors have been proven to be successful extraction systems for RDF. The purpose of these systems is to provide controlled and therefore controllable extraction from the material store. This must occur to an adequate extent from the feeding system's feed control. Linearity of the extraction characteristics is not absolutely essential. A number of simple estimates are listed below to facilitate a better understanding of the extraction characteristics of RDF.

2.1.1 Extraction from below

During extraction from below (Figure 4) the extraction force is introduced into the material from below. Whether the extraction is by screw conveyors, screw extractor floors, chain scraper conveyors or walking floors is of secondary importance.

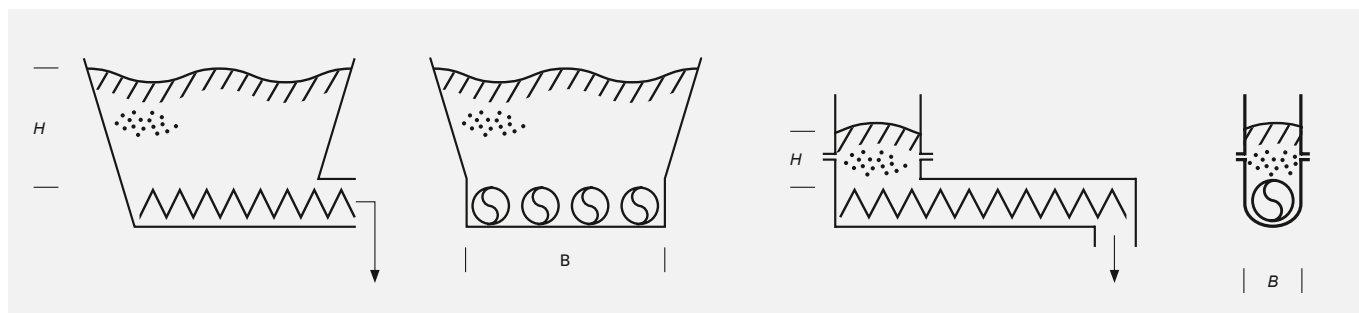

Figure 4: Extraction from below, example of screw trough and screw conveyor

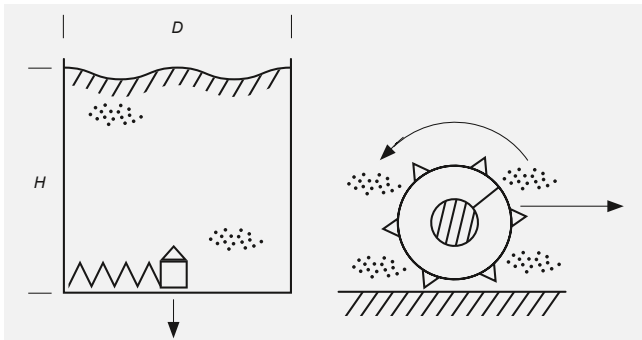

Figure 5: Extraction from below, silo extraction screw conveyor with detail

The following simple relationship applies to extraction from below:

$$H \leq B \text{ (General storage rule)}$$

where

$$H \text{ (storage height)} \tag{1}$$

$$B \text{ (minimum storage width (diameter))}$$

This condition applies universally to all RDF bulk materials. It can also be applied for assessing the geometry of machine inlets and material-filled chutes. Silo extraction using silo extraction screw conveyors (Figure 5) represents an exception to the general storage rule.

In this case, the milling machine function in combination with round silos gives rise to the following relationship:

$$H \leq 2D \text{ (Storage rule for silo extraction screw conveyors)}$$

where

$$H \text{ (storage height)} \tag{2}$$

$$D \text{ (silo diameter)}$$

If these relationships are exceeded, even only locally, bridging always occurs and consequently persistent operational malfunctions.

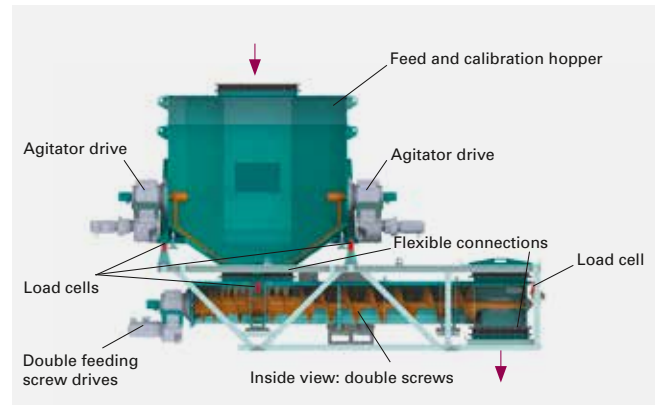

Figure 7: MultiFlex screw weighfeeder

2.1.2 Extraction from above

Large storage volumes can be achieved inexpensively using flat-bottomed hoppers. Typical representatives of these extraction devices are shown in Figure 6.

The first-in-first-out principle is contravened in bunker extraction from above by indoor cranes or by the filling and emptying conveyors. In order to deal with caking and the risk of consolidation with time at the bottom of the bunker, the following simple relationship applies to this type of flat-bottomed hopper:

$$H \leq 3B \text{ (Flat-bottomed hopper storage rule) (3)}$$

where

$$H \text{ (storage height)} \tag{3}$$

$$B \text{ (hopper width)}$$

It may be necessary to reduce the values if the material has a marked tendency to spontaneous ignition.

2.2 Feeding technology

MULTIDOS® belt weighfeeders and MultiFlex screw weighfeeders (Figure 7) have proven successful for feeding alternative fuels [8].

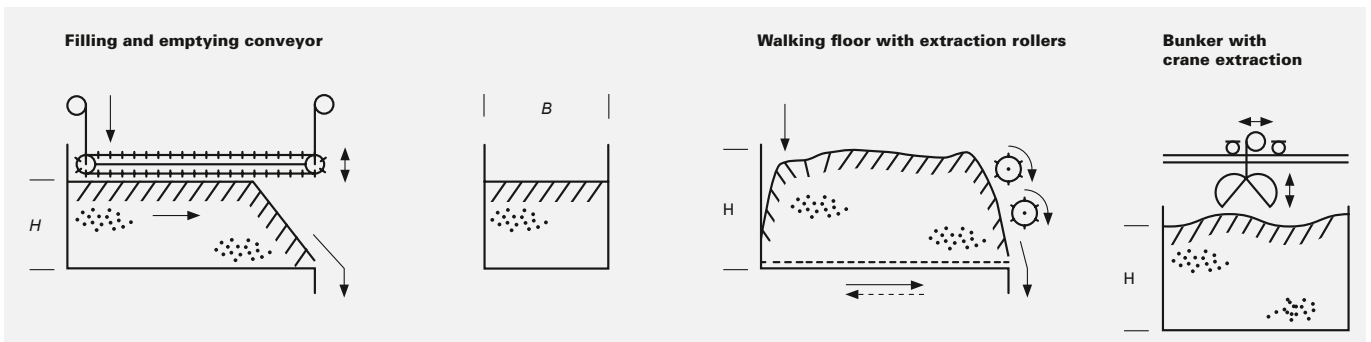

Figure 6: Extraction from above, examples

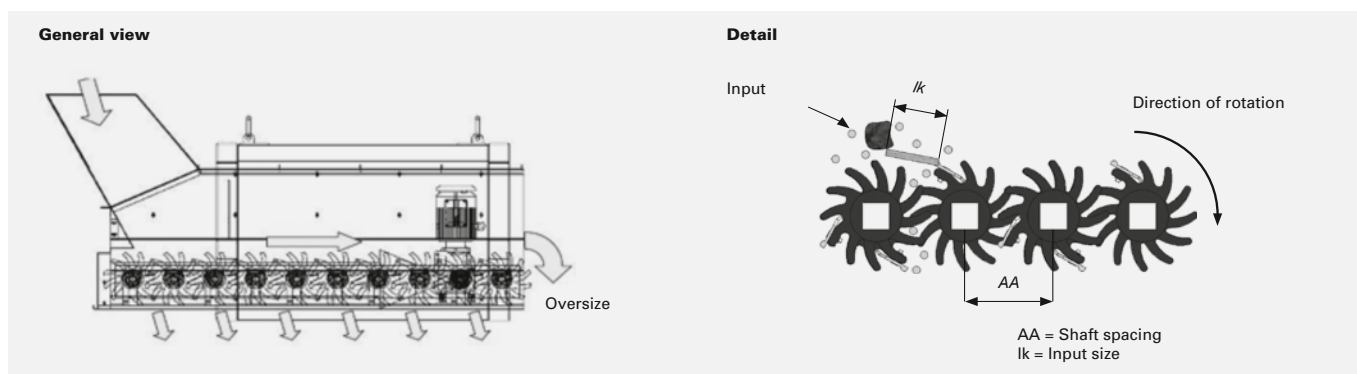

Figure 8: Star screen, structure and functional principle, KOMPTECH GmbH design (www.komptech.com)

Given the lightweight and bulky nature of the transport materials, as well as the high volumetric flows relative to the feed rates, feeders for RDF require generously dimensioned free conveying cross-sections. Blockages caused by fluctuations in the bulk material or by disruptive materials can therefore be safely avoided.

2.3 Dealing with disruptive materials – screening technology and magnetic separators

2.3.1 Star screen

In the context of feeding of alternative fuels, star screens are used exclusively as protective screening machines. The task of a protective screening machine is to reliably protect the downstream sections of plant from disruptive materials. The star screen is not used for fractionation in this case. This is the task of material preparation. The structure and functioning of a star screen are shown in Figure 8.

The main design problem with a protective screening machine lies in choosing the near-mesh material so that the oversized particles, which are always present in small numbers and are not critical to the transport process, are still able to pass through the screen. However, any ultra-large pieces, so-called “disruptive sizes” must be reliably screened. The near-mesh material depends on the grain geometry, the bulk density, the geometry of the screen stars and the rotational speed of the screen shafts. The near-mesh material can be varied within certain limits by adjusting the rotational speed of the screen shafts. A variable frequency drive is generally used with the frequency pre-set during commissioning and therefore the screen shaft speed.

The active gap between the rotating screen stars is extremely important for the functioning of the star screen. If long pieces – “fishes” – attempt to pass through the screen deck, they are forced back by the friction prevailing in the screen gap between the rotating screen stars. The near-mesh material – the screen cut-off – can be changed

within a certain range by adjusting the rotational speed. The rotating fingers on the screen stars ensure intensive mixing of the material on the screen and actively assist in breaking up clumps. The gaps between the screen stars are kept clear by the elastic fingers of the screen stars. The key advantage of this is that the screen area and screen performance are maintained. The parts of the screen deck rotating in the material are made up of elastic screen stars and their elastic intermediate bushings. It is precisely this elasticity in the screen area that avoids jamming and mechanical overload of the screen shafts and their bearings, thereby permanently preventing damage. Another advantage of star screens is the ability to use screen elements of different widths while maintaining the screen shaft distance and therefore to adapt the near-mesh material in the installed system at short notice and in a simple manner, for example during on-site troubleshooting.

2.3.2 Magnetic drum separator

Processed RDF always contain small amounts of ferromagnetic material. RDF can also become contaminated by pieces of metal during transport and storage. Magnetic drum separators are used to remove these highly abrasive,

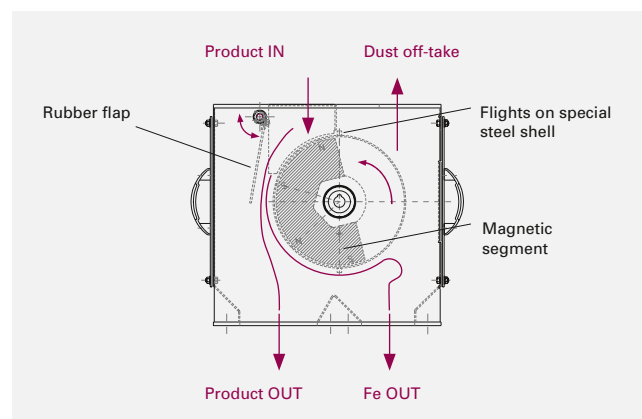

Figure 9: Operating principle of the magnetic drum separator, GOUDSMIT Magnetics Group design (www.goudsmitmagnets.com)

disruptive, ferromagnetic materials from the process. The magnetic drum separator has proven particularly successful because of its compact and enclosed design and the pre-fed distribution of the material. The rotating drum is fitted with an adjustable permanent magnet. The operating principle is shown in Figure 9.

The drum of the magnetic separator consists of a stationary magnetic segment and a non-magnetic stainless steel shell. The shell is driven by a motor and rotates in the direction of the product flow. The magnetic segment does not move. The ferromagnetic particles are attracted by the magnetic segment and adhere to the shell. The non-magnetic product drops down vertically. The iron particles are transported to the non-magnetic part of the drum. The magnetic field does not act here, which means that the iron particles fall out of the drum into the iron outlet duct. The alternative fuel falls through the product outlet and out of the unit. The iron particles are transported via a stainless steel, rubber or plastic chute into a collecting container.

2.4 The chute – more than a piece of sheet metal

Chutes are an important part of RDF plants and not, as one might at first think, simply connecting elements made from sheet metal. Chutes have the task of directing the flow of material so that it travels in the ideal manner for the downstream machine without overloading it or blocking it. Depending on the design, a distinction is made between accelerating, delaying, spreading and narrowing chutes (Figure 10). Often, chutes are also tasked with dust collection.

All chutes, given their propensity towards blocking with inspection openings and fill level probes, must be equipped with blockage sensors. These are installed at critical points in the chute and shut the system down if a blockage is imminent (cf. Section 2.1.1, General storage rule).

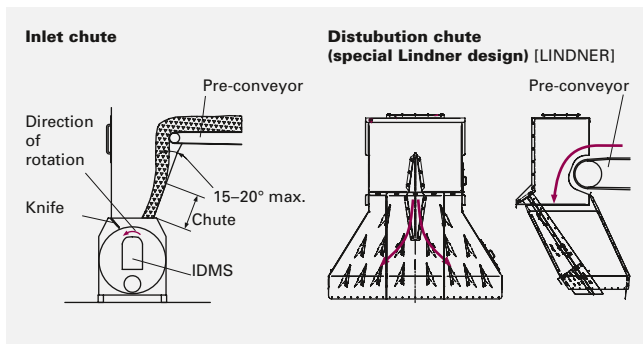

Figure 10: Chute geometry and material guidance

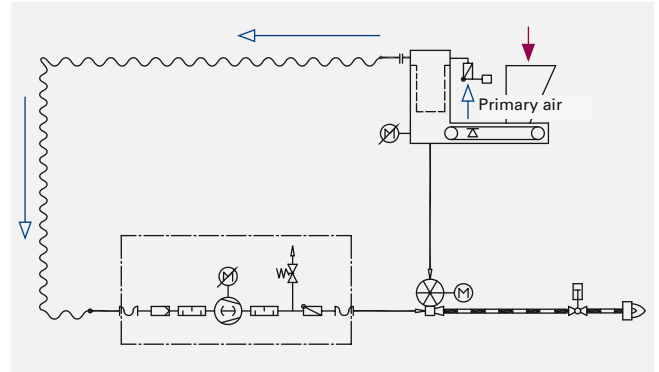

Figure 11: Leakage air dust collection with exhaust air return

2.5 The dependable filter – requirements on filter technology

In many cases the alternative fuels (RDF) transported into the feeding units are harmful to health, nauseating and sometimes also toxic. An effective dust collection system is therefore needed to protect the plant personnel and the environment. The dust collection system has to keep the plant under a slight negative pressure to avoid the escape of dust, unpleasant odors and gases that are harmful to health. This is particularly true of the dust collection system in the pneumatic conveying area. This is where the material and conveying air are thoroughly mixed, favoring the generation of dust and odors.

The principle of exhaust air return (Figure 11) has proved particularly successful for the dust collection system when the burner is fed by pneumatic conveying. The leakage air escaping from the rotary valve is loaded with moisture from the material due to the hot air from the blower. Condensation occurs immediately if this saturated moist air meets the cool outer wall of the filter housing; water collects, seeps into the filter elements and clogs them – with the result that the filter becomes blocked and the dust collection system no longer functions.

This scenario is prevented if the clean gas side of the filter is flushed with external air and therefore counteracts any local fall below the dew point. The external air flows into the clean gas side through a weighted flap, which permanently ensures the vacuum necessary for the overall function of the filter. The vacuum is generated via the extraction at the suction piece on the clean gas side of the filter. Either a ventilator is used as the exhaust fan or the material transport blower itself in the context of pneumatic conveying.

The advantage of the exhaust air return described above is that the material transport blower used to aspirate the filter is used. This is an environmental resource that is generally

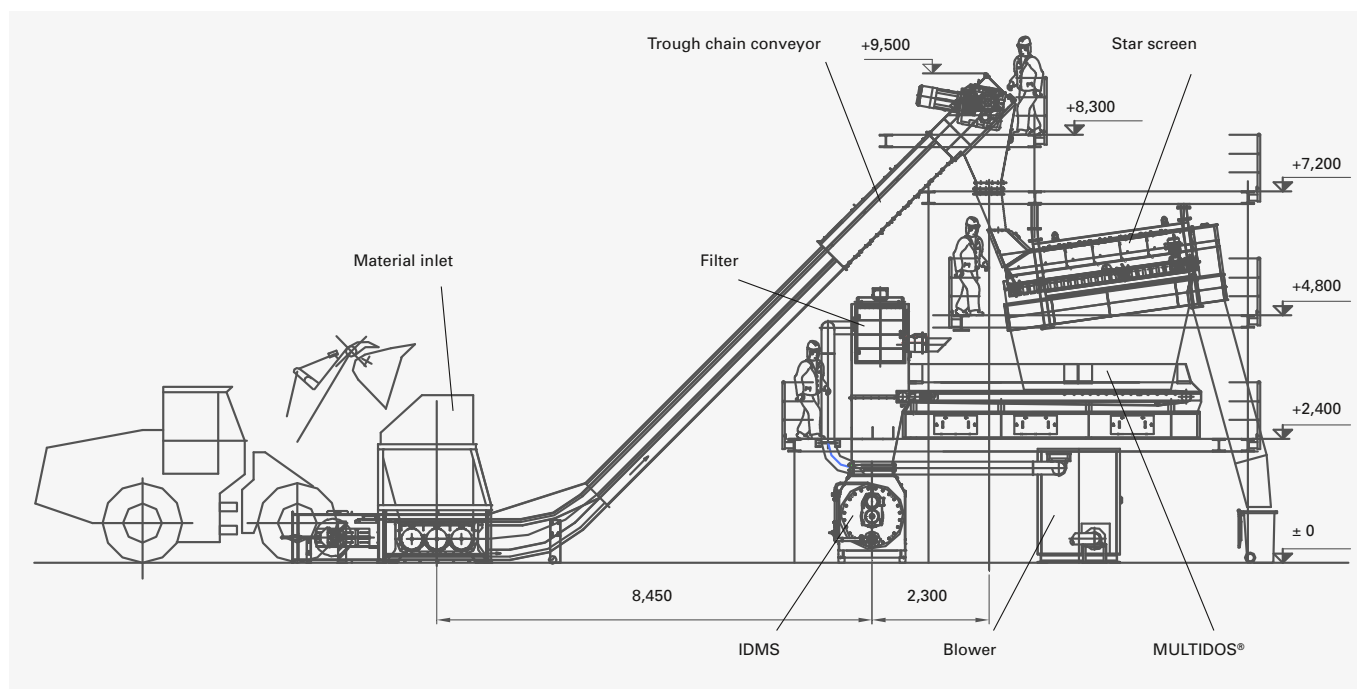

Figure 12: "Starter kit" simple feeding line construction

available with every pneumatic conveying system. By returning the clean gas from the filter to the pneumatic conveying system, all volatile exhaust air components, such as bad odors and vapors that are harmful to health, disappear in the combustion process.

2.6 Starter kit feeding line

With the installation of a starter kit feeding line (Figure 12), the customer has the option of testing various materials in their kilns in an inexpensive and reliable manner, thereby protecting larger investments made at a later date from a technical perspective.

3 Problems with introducing the material into the system – evolution of the rotary valve

3.1 Obstructions and blockages

The main task of rotary valves for alternative fuels lies in the introduction of the very lightweight, abrasive, sticky and bulky materials into a relatively narrow conveying line which is under positive pressure. To keep the leakage air within acceptable limits, the gap between the cellular rotor and the housing is reduced to a minimum and maintained as far as possible during the operation. If, due to extremely disruptive materials and the resulting damage of the sealing gap, there is a dramatic increase in the leakage air and this is not immediately offset by adjusting the amount of conveying air, then the lack of conveying air causes failure of the pneumatic conveying system and blockage of the conveying line.

At the inlet area of the rotary valve there is the problem of filling the chambers of the cellular rotor sufficiently well with material. On the one hand this is ensured by the supply of material, which is pre-fed as uniformly as possible. On the other hand the material must be supplied to the rotary valve distributed over the entire length of the chamber so that local overfilling and blockage of the cellular rotor is avoided. As well as pre-feeding, this is the key task of the inlet chute (cf. Section 2.4). The material must be transferred into the delivery line in the valve's outlet area. With very lightweight and bulky materials such as the group of alternative fuels (RDF), this is not always possible.

3.2 From the discharge valve to the injector blow-through rotary valve

By way of introduction, a brief history and the evolution of rotary valves for alternative fuels will now be described (Figure 13).

In terms of the history of bulk material technology, alternative fuels are a very young material, therefore there was no salient or tangible experience available at the start of the first considerations for building a rotary valve. A wide variety of solutions was tried out. One of the first rotary valve systems consisted of the combination of a discharge rotary valve with integrated knives and a feeding shoe. However, the feeding shoe proved to be a problem as it blocked very rapidly with bulky and lightweight materials and therefore required constant cleaning.

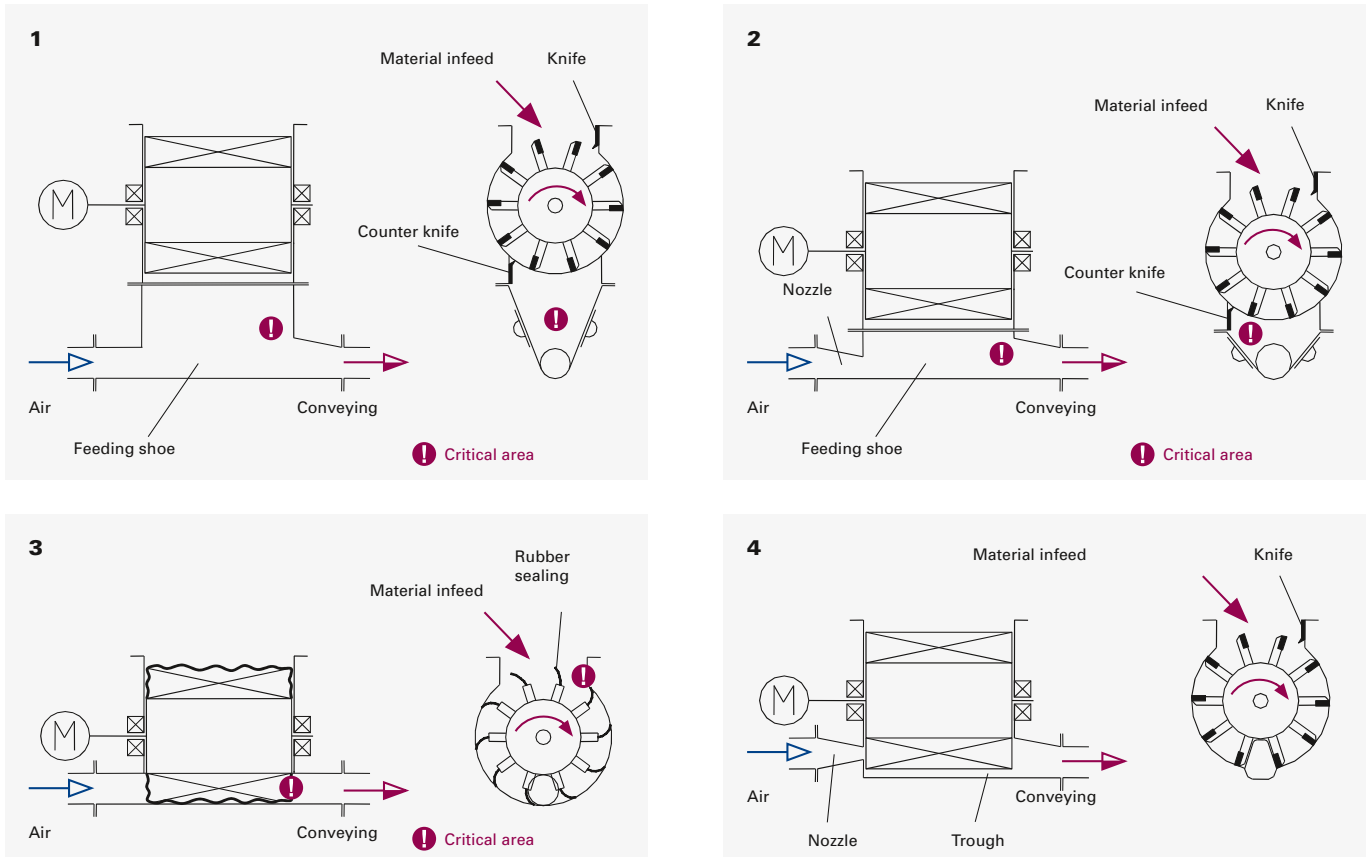

Figure 13: Chronology of the evolution of rotary valves 1 to 4

This typical problem was overcome by changing the function of the feeding shoe to that of an injector shoe and integrating a nozzle into it. At the same time it was moved closer to the discharge rotary valve. With the increasing scarcity of alternative fuels – due to the rising demand for them in the marketplace as fuels – there was a dramatic fall in quality, so this system also came up against its natural limits.

This was when the blow-through rotary valve for alternative fuels came into being. Starting from the experience gained with the familiar blow-through rotary valve, the attempt was then made to blow the material directly out of the cellular rotor chambers with conveying air. In a classical blow-through rotary valve the chamber cross-section that can be blown through is closely linked to the diameter of the conveying line [2]. However, this circumstance could only be partially taken into account in the design due to the large cellular rotor chambers needed for the waste material. The chambers in these valves therefore became blocked repeatedly due to incomplete emptying in the discharge area. This occurred because material became stuck between the cellular rotor and the discharge opening.

The problem was overcome by fitting the cellular rotor with soft sealing lips – with the disadvantage that these rubber sealing strips were damaged very quickly by hard disruptive material, resulting in a dramatic rise in leakage air during operation. Failure of the pneumatic conveying system was the inevitable consequence. The wear on the rubber sealing lips increased rapidly as the quality of the alternative fuels deteriorated, which meant that either the rubber sealing lips had to be replaced very frequently at short notice or the possible length of conveying line and the associated pipeline back pressures had to be sharply reduced. Both measures would have meant a retrograde step in the technology, which was contrary to the rising demands of the market.

Based on this experience the onward development of the rotary valve for alternative fuels led away from the blowthrough rotary valve with “soft” seals to the blow-through rotary valve with “hard” seals and integral injector nozzle. The resulting technology of the injector blow-through rotary valve (IDMS) is described below.

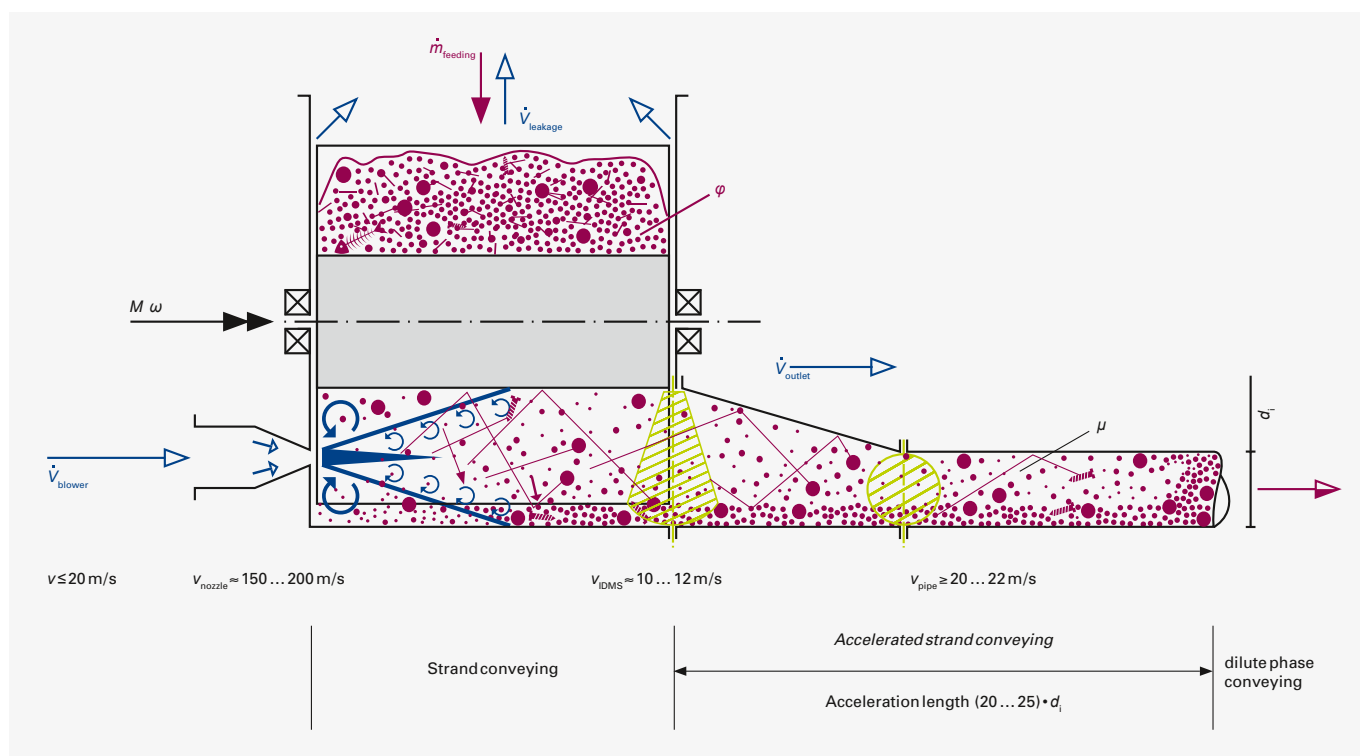

Figure 14: Operating principle of the injector blow-through rotary valve (IDMS)

3.3 Solution to a technical conflict

Alternative fuels (RDF) belong to the group of difficult bulk materials because many of the material parameters, such as bulk density, moisture, grain size and grain shape are subject to sharp fluctuations during operation. Severely abrasive material properties are an additional complication. In the plant design and choice of components the unfavorable material properties are usually dealt with by using a very robust mechanical design. The main aim in this application is to achieve a high level of availability under rough operating conditions.

If a very lightweight, bulky and sometimes also sticky material is to be introduced into a relatively narrow conveying line that is also under positive pressure, then this inevitably involves technical conflict. A large volume flow, resulting from the low bulk density, requires large cellular rotor chambers, but these must then feed the material into

a narrow conveying line without causing a blockage. The solution to this conflict is illustrated in Figure 14.

In contrast to a classical blow-through rotary valve, an injector nozzle ensures efficient discharge and emptying of the cellular rotor. When the conveying air enters the cellular rotor chamber, the injector nozzle generates a high local air velocity. This in turn transmits a high velocity impulse to the material to be accelerated over a very short distance and ensures that the cellular rotor chamber is completely emptied. Intensive mixing of the material at the discharge area takes place due to the high relative velocity of the injector jet. Bulky particles and disruptive materials that are always present in RDF become embedded in the material flow and are fed into the conveying line. All this takes place within the IDMS within the shortest possible time without the cellular rotor jamming or the outlet blocking. Figure 15 shows the implementation and structural design of the injector blow-through rotary valve (IDMS).

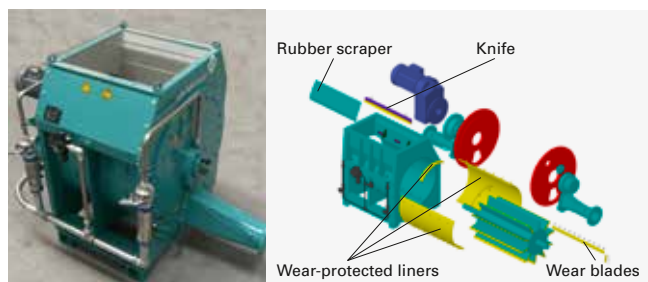

Figure 15: IDMS 120, wear system

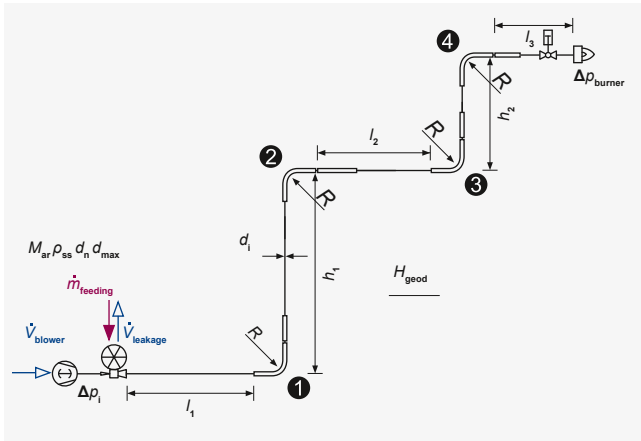

Figure 16: Conveying line and its influencing factors

4 Pneumatic conveying

4.1 Conveying line – requirements and influencing factors

During the pneumatic conveying of alternative fuels (RDF), it is necessary to take not only the isometry but also the critical material properties into consideration. The key contexts are illustrated in Figure 16.

The functioning of the conveying line depends on numerous factors. If these are not taken into account then pulsation will occur in the conveying line, which can become a problem when feeding the burner, and in the worst case can lead to blockages in the conveying line. A few of the key requirements are listed below. Including: loading, empty-pipe velocity, route of the conveying line, radii of curvature and design of pipe bends, type of conveying pipes, type of flange connections used, the diameter of the conveying line and the type of material mixtures involved. The details of this can be found in [3].

With an understanding of the factors it is possible, starting from the material (RDF), to derive simple conditions. Starting from the material specification (cf. Section 1.2) and bearing in mind the generally recognized process engineering design principles for pneumatic delivery lines [3], the following unidimensional description can be drawn up for the grain definition according to [9] and [10]:

$$d = 0 \dots d_n \text{ where } x [\%] \text{ max. } d_{\text{max}} \text{ (grain size, unidimensional)}$$

where

$$d_n \text{ (nominal grain size, main element)} \quad (4)$$

$$d_{\text{max}} \text{ (oversized particles)}$$

$$x \text{ (percentage of oversized particles)}$$

The coarser the material, the more oversized particles must be expected.

With this definition of particles, the condition for the conveying line diameter and clearance of the conveying line can be established to prevent blockages in the area of the pneumatic conveying line by materials with large flakes.

$$d_i \geq \begin{cases} (3 \dots 4) d_n \text{ for 2D material (soft/fluffy)} \\ (4 \dots 5) d_n \text{ for 3D material (hard, not fluffy)} \\ d_{\text{max}} \text{ for 2D and 3D material (hard or fluffy)} \end{cases} \quad (5)$$

where

d_i (internal diameter of the conveying line)

The more hard grain sizes contained in the material, the thicker the conveying line.

Below, Table 1 shows an example of empirical figures that illustrate this relationship:

These relationships are based on empirically determined

d_n [mm]	x [%]	d_{max} [mm]	d_i	IDMS type
0–30	3	50	DN 125	IDMS 60
0–40	3	80	DN 150	IDMS 80
0–60	3	100	DN 200	IDMS 100
0–80	5	150	DN 250	IDMS 120

Table 1: Example of figures with $d_i \approx 4d_n$ and $d_{\text{max}} \approx 2d_n$

values. The highly simplified assumptions made are of a heuristic nature and do not replace careful material analysis and its detailed evaluation by an expert.

4.2 Pneumatic feeding – making the installation more flexible

An impression of the potential of pneumatic conveying of alternative fuels is given below (Figure 17). The pneumatic conveying system transports the alternative fuels, possibly coming from a silo outlet, by an injector blow-through rotary valve (IDMS) over great distances and height differences directly into the MultiFlex screw weighfeeder. All the conveying air is collected in a special total separator above the MultiFlex feeder and therefore does not enter the combustion process in the calciner as disruptive cold air. The material falls directly from the total separator into the weighing hopper of the MultiFlex positioned underneath where it acts as a material buffer for the weighing process and at the same time as an air seal to the combustion process.

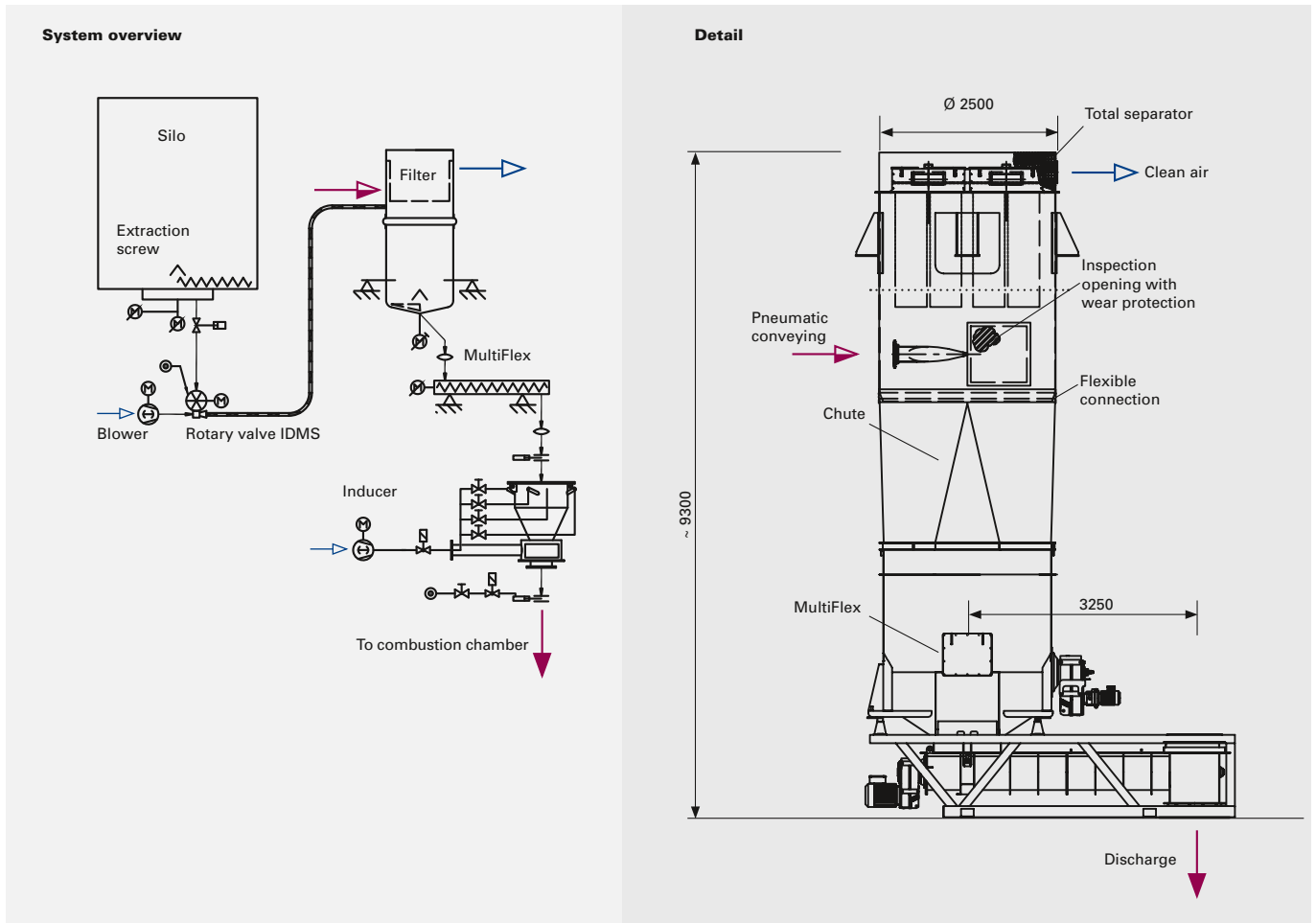

Figure 17: Pneumatic pre-feed to the MultiFlex feeder

The robustness of the IDMS ensures that the pneumatic conveying system has a high level of availability. There is no need for a vulnerable and often complicated mechanical pre-conveyor. Star screens and magnetic separators can be integrated to suit the material requirements and this improves the availability of the entire plant still further. This configuration makes it easy to carry out any adjustments to suit the installation site resulting from recently acquired operating experience. Rapid retrofitting to existing systems is made significantly easier.

5 Summary and outlook

This article has attempted to describe the fundamental understanding of how alternative fuels can be conveyed. Starting from practical observations, it is possible to detect initial heuristic patterns and potential solutions that can help to deal more reliably with alternative fuels. It is now the task of science to dedicate more research work to this bulk material.

Practical evidence has been produced of the feasibility of the pneumatic conveying of alternative fuels over great

distances. The theory on the expansion of calculation principles will follow. It can be assumed that the successful implementation of pneumatic materials handling will continue to increase. In the areas close to the system especially where limited space and system flexibility are needed, pneumatic conveying will close a gap. New pneumatic conveying processes are already conceivable today and are awaiting implementation.

The handling of alternative fuels is complex. Many design parameters, by their nature, involve a high degree of uncertainty and can, over the course of the system's operation, suddenly and unexpectedly change, which in extreme cases can result in the total failure of system-critical components. To take account of these unavoidable uncertainties, intelligent system components are of particular interest. The failure of system-critical components will in future be increasingly countered by improving their protection by procuring local intelligence [5] and therefore significantly further increasing plant availability.

Dipl.-Ing. TU Harald Faber
Schenck Process Europe GmbH

Directory of sources:

- [1] SCHULZE, Dietmar: Fließeigenschaften von Schüttgütern mit faser- und plättchenförmigen Partikeln – Schüttgut 8 (2002) 6, pages 538–546
- [2] SIEGEL, Wolfgang: Pneumatische Förderung: Grundlagen, Auslegung, Anlagenbau, Betrieb. 1th ed. – Würzburg: Vogel Buchverlag – 1991
- [3] Schenck Process BVR2272: Allgemeine verfahrenstechnische Auslegungsgrundsätze für pneumatische Förderanlagen für alternative Brennstoffe – 2012
- [4] Schenck Process BV-D2243: Datenblatt – Durchblasmesserschleuse IDMS 60/80/100/120 – 2014
- [5] Schenck Process BV-D2434: Datenblatt – Steuerungs- und Überwachungseinheit für Zellenradschleuse IDMS – 2014
- [6] Harald Faber, Klaus Rupp: Schenck Process BV-S2028: Sonderdruck – Bevorratung, Dosierung und Förderung von festen Sekundärbrennstoffen – Konzepte und Equipment: Cement International, – 12/2007, vol. 06, page 16
- [7] Klaus Rupp, Harald Faber: Schenck Process BV-A1039: At a glance – feeding alternative fuels – 2010
- [8] Frank Thomasberger, Harald Faber: The Practicalities of Handling Alternative Fuels: Reprint from World Cement – 03/2012, page 5
- [9] Harald Faber: Pneumatic Handling of Alternative Fuels: An Experience Report from the Industry for the Industry: 20th Expert Conference on Bulk Materials Conveying Technology – Magdeburg, 2015, pages 257 – 275
- [10] Harald Faber: Handling Alternative Fuels – A Progress Report: Cement International, 1/2016, vol. 14, pages 68 – 79
- [11] EN 15357: Solid recovered fuels – Terminology, definitions and descriptions – 2011
- [12] CEN-TS 15401: Solid recovered fuels – Determination of bulk density – 2010
- [13] EN 15415-1 Solid recovered fuels – Determination of particle size distribution – Part 1: Screen method for small dimension particles – 2011
- [14] CEN/TS 15414 Solid recovered fuels – Determination of moisture content using the oven dry method – Part 2: Determination of total moisture by a simplified method – 2010



Schenck Process Europe GmbH
Pallaswiesenstr. 100
64293 Darmstadt, Germany
T +49 61 51-15 31 0
sales@schenckprocess.com
www.schenckprocess.com